

# RUSSELL STREET

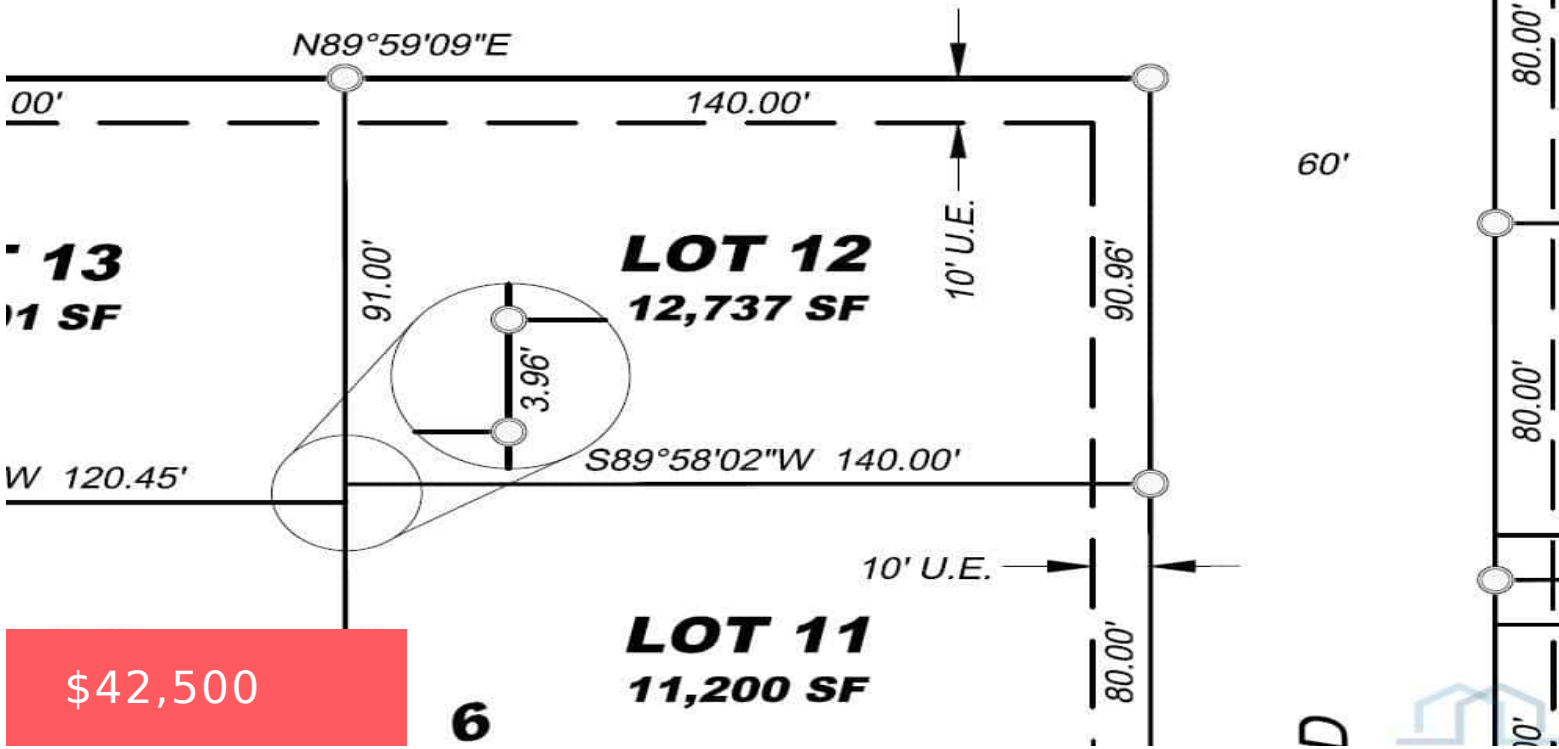

Lot 12 Block 6 Country Club Estates Elk Point City, Union County, SD

- Building Site/Land, Residential
- Active

## Basics

**Category:** Building Site/Land, Residential

**Status:** Active

**Lot size:** 16312 sq ft

## Agent



**Agent First Name:** Troy

**Agent Last Name:** Donnelly

**Agent Email:** tdonnelly@iw.net

**Agent Phone Number:** 712-899-3748

